

COINTRAP helmet 15 UN divider

patented technology

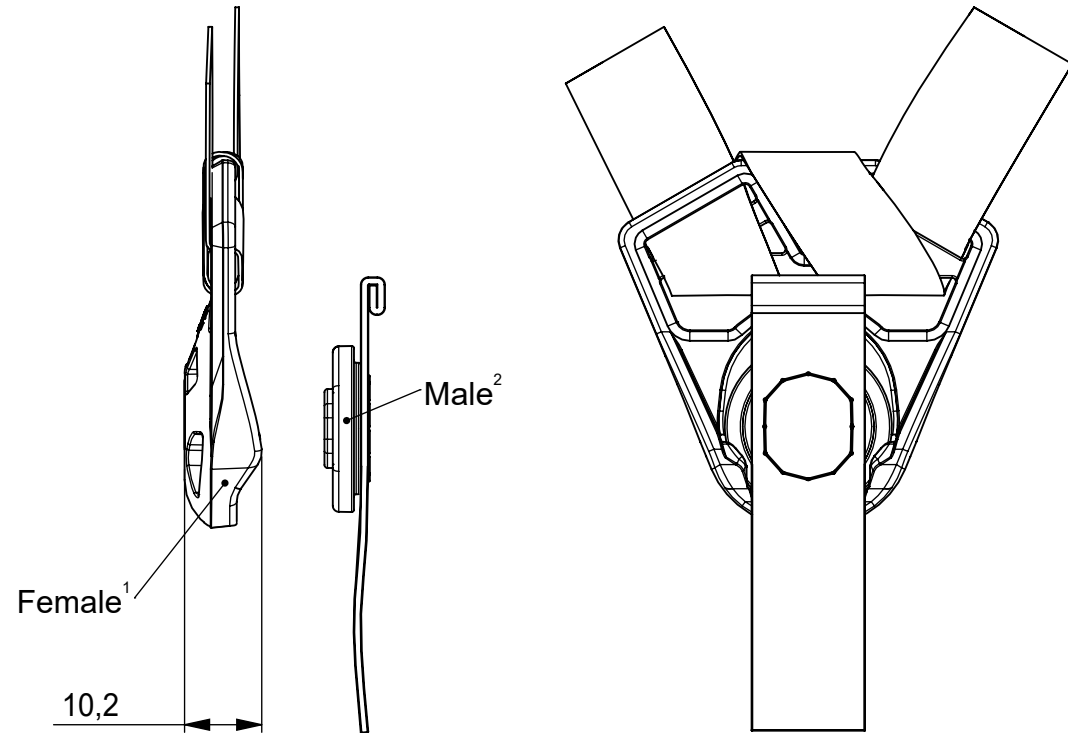
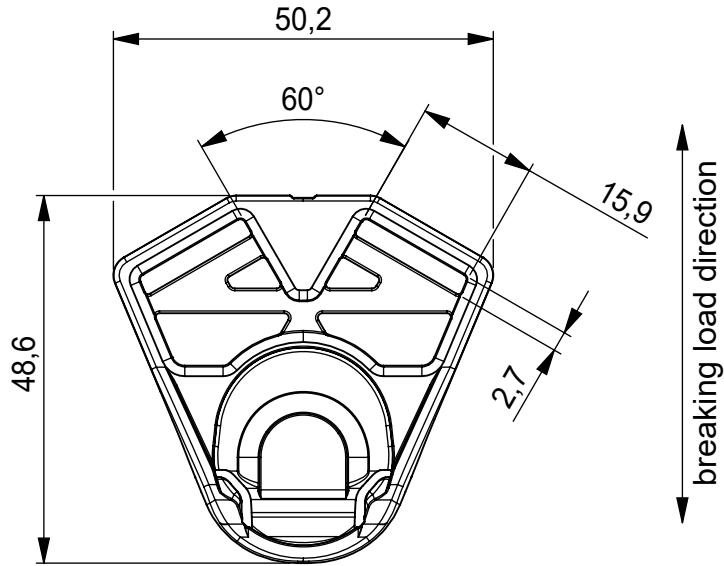

NOTE:

The positioning of the product on the helmet may vary depending on the size and construction, especially in the case of children's helmets. The specific application and suitability test must be carried out by the helmet manufacturer.

nominal values in millimeters [mm]

OPENING	lifting
MATERIAL	PA6 GF/CF ¹ , PA66 GF ² , NdFeB, Epoxy
COLOUR	Black
WEIGHT	~ 8,7 g (weighed)
BREAKING LOAD**	710 N

GENERAL NOTES*

Designed for use in products that comply with the following standards
DIN EN 1078:2014-04, AS/NZS 2063:2020, ASTM F1447-18.

Webbing not included.

ARTICLE NO.	07076
PRODUCT	COINTRAP helmet 15 UN divider
SCALE	1:1 DIN A4
REVISION / DATE	R00 13.06.24

* The manufacturer of the end products in which FIDLOCK fasteners are used, bears the responsibility for thoroughly testing that the FIDLOCK products are suitable for the intended applications.

** According to test specification QM-TP-001